

User's and Service Guide

Agilent Technologies 85051B 7 mm Verification Kit

This manual applies directly to 85051B Verification Kits that have serial number prefix 2815A. The verification devices in this kit are individually serialized.



Manufacturing Part Number: 85051-90031

Printed in USA

Print Date: June 2002

Supersedes: August 1995

© Copyright 1995, 2002 Agilent Technologies, Inc. All rights reserved.

Documentation Warranty

THE MATERIAL CONTAINED IN THIS DOCUMENT IS PROVIDED "AS IS," AND IS SUBJECT TO BEING CHANGED, WITHOUT NOTICE, IN FUTURE EDITIONS. FURTHER, TO THE MAXIMUM EXTENT PERMITTED BY APPLICABLE LAW, AGILENT DISCLAIMS ALL WARRANTIES, EITHER EXPRESS OR IMPLIED WITH REGARD TO THIS MANUAL AND ANY INFORMATION CONTAINED HEREIN, INCLUDING BUT NOT LIMITED TO THE IMPLIED WARRANTIES OF MERCHANTABILITY AND FITNESS FOR A PARTICULAR PURPOSE. AGILENT SHALL NOT BE LIABLE FOR ERRORS OR FOR INCIDENTAL OR CONSEQUENTIAL DAMAGES IN CONNECTION WITH THE FURNISHING, USE, OR PERFORMANCE OF THIS DOCUMENT OR ANY INFORMATION CONTAINED HEREIN. SHOULD AGILENT AND THE USER HAVE A SEPARATE WRITTEN AGREEMENT WITH WARRANTY TERMS COVERING THE MATERIAL IN THIS DOCUMENT THAT CONFLICT WITH THESE TERMS, THE WARRANTY TERMS IN THE SEPARATE AGREEMENT WILL CONTROL.

Assistance

Product maintenance agreements and other customer assistance agreements are available for Agilent products.

For any assistance, contact Agilent Technologies. Refer to [page 6-4](#) for a list of Agilent contacts.

1. General Information

Verification Kit Overview	1-2
Kit Contents	1-2
Compatible Network Analyzers	1-2
Equipment Required but Not Supplied	1-3
Incoming Inspection	1-3
Recording the Device Serial Numbers	1-4
Preventive Maintenance	1-4

2. Specifications

Environmental Requirements	2-2
Temperature—What To Watch Out For	2-2
Mechanical Characteristics	2-3
Center Conductors	2-3
Airline Mechanical Characteristics	2-4
Electrical Specifications	2-6

3. Duplicating Your Verification Data

Using an 8510C Network Analyzer	3-2
Using an HP Series 200/300 Controller	3-3
Using an 8719, 8720, or 8722 Series Network Analyzer	3-4
Using a PNA Series Network Analyzer	3-5
Format a Blank Disk	3-5
Copy the Data Disk	3-5

4. Use, Maintenance, and Care of the Devices

Electrostatic Discharge	4-2
Visual Inspection	4-3
Look for Obvious Defects and Damage First	4-3
Inspect the Mating Plane Surfaces	4-3
Cleaning Connectors	4-4
Gaging Connectors	4-6
Connector Gage Accuracy	4-6
When to Gage Connectors	4-6
Reading the Connector Gage	4-7
Gaging Procedure	4-8
Gaging the Airline	4-10
Making Connections	4-12
How to Make a Connection	4-12
Connecting the Airline	4-14
How to Separate a Connection	4-17
Handling and Storage	4-18

Contents

5. Performance Verification

- Introduction 5-2
- How Agilent Verifies the Devices in Your Kit. 5-2
- Recertification 5-3
 - How Often to Recertify 5-3
 - Where to Send a Kit for Recertification. 5-3

6. Troubleshooting

- Troubleshooting Process 6-2
- Compatible Network Analyzers 6-2
- Returning a Kit or Device to Agilent Technologies 6-4
- Contacting Agilent 6-4

7. Replaceable Parts

- Introduction 7-2

1 General Information

Verification Kit Overview

The Agilent 85051B 7 mm verification kit provides a set of standards with known characteristics, traceable to a reference (golden) standard in Agilent Technologies calibration lab. This set of standards is used to verify your measurement calibration and also to verify that your network analyzer system is operating within its specifications. The frequency range covered by the 85051B is from 45 MHz to 18 GHz.

Kit Contents

The 85051B verification kit includes the following items:

- 20 dB attenuator
- 50 dB attenuator
- 25 Ω mismatch airline
- 50 Ω airline
- three data disks that contain factory-measured verification data of the devices in this kit

Refer to [Chapter 7, "Replaceable Parts,"](#) for a complete list of kit contents and their associated part numbers.

NOTE A file containing the verification data for your kit is maintained for one year from the time of measurement. If you lose this data, contact Agilent. See [Table 6-1 on page 6-4](#) for a list of contacts.

Compatible Network Analyzers

The 85051B verification kit is intended to be used with the 85050B/C/D 7 mm calibration kits and any of the following Agilent network analyzers:

- 8510
- 872x series
- PNA series

If this calibration kit is used with other analyzers, the calibration constants must be manually entered into the analyzer. Refer to your network analyzer user's guide or embedded help system for instructions.

Equipment Required but Not Supplied

The following items are required or recommended for successful operation of your kit, but are not supplied with the kit.

- 7 mm connector gage kit
- 3/4 inch, 136 N-cm (12 in-lb) torque wrench
- male short circuit (for gaging the airlines)
- collet extractor tool
- connector cleaning supplies

Refer to [Table 7-2 on page 7-3](#) for ordering information.

Incoming Inspection

Verify that the shipment is complete by referring to [Table 7-1](#).

Check for damage. The foam-lined storage case provides protection during shipping. Verify that this case and its contents are not damaged.

If the case or any device appears damaged, or if the shipment is incomplete, contact Agilent Technologies. See [page 6-4](#) for contact information. Agilent will arrange for repair or replacement of incomplete or damaged shipments without waiting for a settlement from the transportation company. Refer to [“Returning a Kit or Device to Agilent Technologies” on page 6-4](#) for instructions.

Recording the Device Serial Numbers

In addition to the kit serial number, the devices in this kit are individually serialized (serial numbers are labeled into the body of each device). Record these serial numbers in [Table 1-1](#). Recording the serial numbers will prevent confusing the devices in this kit with similar devices from other kits.

Table 1-1 Serial Number Record for the 85051B

Device	Serial Number
Verification kit	_____
20 dB attenuator	_____
50 dB attenuator	_____
50Ω airline	_____
25Ω mismatch airline	_____

Preventive Maintenance

The best techniques for maintaining the integrity of the devices in this kit include:

- routine visual inspection
- cleaning
- proper gaging
- proper connection techniques

All of these are described in [Chapter 4](#), “[Use, Maintenance, and Care of the Devices.](#)” Failure to detect and remove dirt or metallic particles on a mating plane surface can degrade repeatability and accuracy and can damage any connector mated to it. Improper connections, resulting from pin depth values being out of specification (see [Table 2-2 on page 2-4](#)), or from bad connection techniques, can also damage these devices.

2 Specifications

Environmental Requirements

Table 2-1 Environmental Requirements

Parameter	Required Values/Ranges
Temperature	
Operating ^a	+20 °C to +26 °C
Storage	-40 °C to +71 °C
Error-corrected range ^b	±1 °C of measurement calibration temperature
Altitude	
Operating	< 4,500 meters (≈15,000 feet)
Storage	< 15,000 meters (≈50,000 feet)
Relative humidity	Always non-condensing
Operating	0 to 80% (26 °C maximum dry bulb)
Storage	0 to 90%

- a. The temperature range over which the calibration standards maintain conformance to their specifications.
- b. The allowable network analyzer ambient temperature drift during measurement calibration and during measurements when the network analyzer error correction is turned on. Also, the range over which the network analyzer maintains its specified performance while correction is turned on.

Temperature—What To Watch Out For

Due to the small dimensions of the devices, electrical characteristics will change with temperature. Therefore, the operating temperature is a critical factor in their performance, and must be stable before use.

IMPORTANT Avoid unnecessary handling the devices during use because your fingers are a heat source.

Mechanical Characteristics

Mechanical characteristics such as center conductor protrusion and airline dimensions are *not warranted* performance specifications. They are, however, important supplemental characteristics related to electrical performance. Agilent Technologies verifies the mechanical characteristics of the devices in this kit with special gaging processes and electrical testing. This ensures that the device connectors do not exhibit any improper pin depth when the kit leaves the factory.

“Gaging Connectors” on page 4-6 explains how to use gages to determine if the kit devices have maintained their mechanical integrity. Refer to Table 2-2 on page 2-4 for typical and observed pin depth limits.

Center Conductors

In 7 mm connectors, the maximum allowable protrusion of the center conductor with the center conductor collet in place is 0.015 inches. The minimum protrusion required is 0.002 inches.

Figure 2-1 7 mm Attenuators

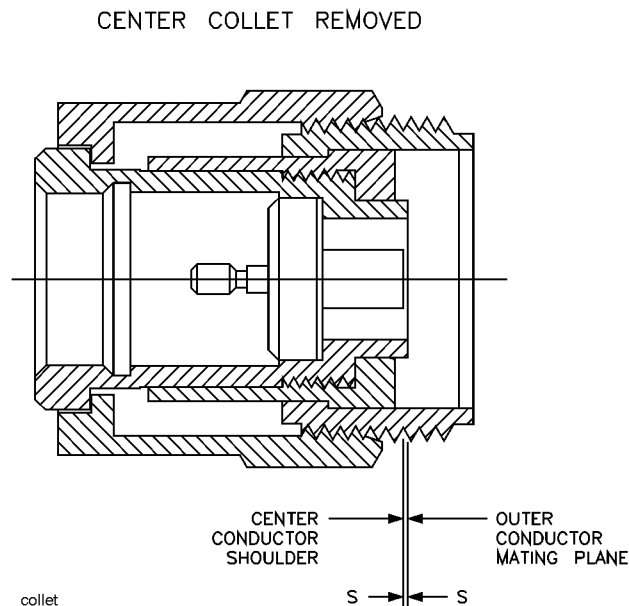

S = recession of the center conductor shoulder behind the outer conductor mating plane

NOTE The factory uncertainty of the numbers given in the following table is less than ± 0.0001 inch. Gage accuracy is also ± 0.0001 inch.

Table 2-2 Connector Pin Depths

Connectors	Allowable Recession	
	millimeters	inches
Attenuators center collet removed	0.0000 to +0.0500	0.000 to +0.0020
Airlines ^a center pin removed	+0.0025 ^b to -0.0100	+0.0001 ^b to -0.0004

- a. The relationship between the length of the inner conductor and the length of the outer conductor determines the airline center conductor recession. Refer to [“Gaging the Airline” on page 4-10](#).
- b. In this case, the center conductor is 0.0001 inch (0.0025 mm) longer than the outer conductor.

Using these mechanical dimensions, you can calculate the expected electrical performance with the equations in the following publications:

- Nelson, Robert E., and Marlene R. Coryell, "Electrical Parameters of Precision, Coaxial, Air-Dielectric Transmission Lines", U.S. National Bureau of Standards Monograph No. 96.
- Somlo, P.L., "The Computation of Coaxial Line Step Capacitances", IEEE Transactions on Microwave Theory and Techniques, Volume MTT-15, No. 1, January, 1967.

The measurement method in these publications provides a general idea of the expected device characteristic impedance. Variations in connector interfaces can have a large effect on your actual electrical measurements.

Airline Mechanical Characteristics

The dimensions of the airline outer conductor are shown in [Figure 2-2](#). This outer conductor is common to both airlines. Two conductors are provided with the kit.

The dimensions of the 50Ω airline and the 25Ω mismatch airline are shown in [Figure 2-3](#) and [Figure 2-4](#).

CAUTION The center and outer conductors of the airlines in this kit have been mechanically measured and matched. Do *not* use the center or outer conductors provided in this kit with a center or outer conductor from any other airline. Damage to the airline or attaching connector may result.

Figure 2-2 Airline Outer Conductor

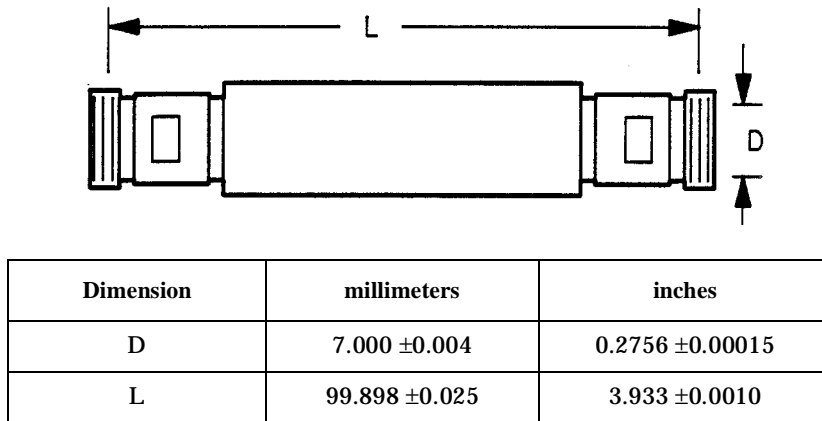

Figure 2-3 50 Ω Airline Center Conductor

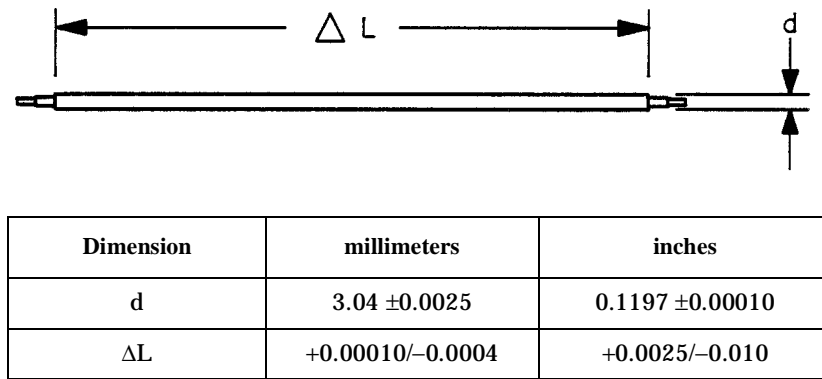
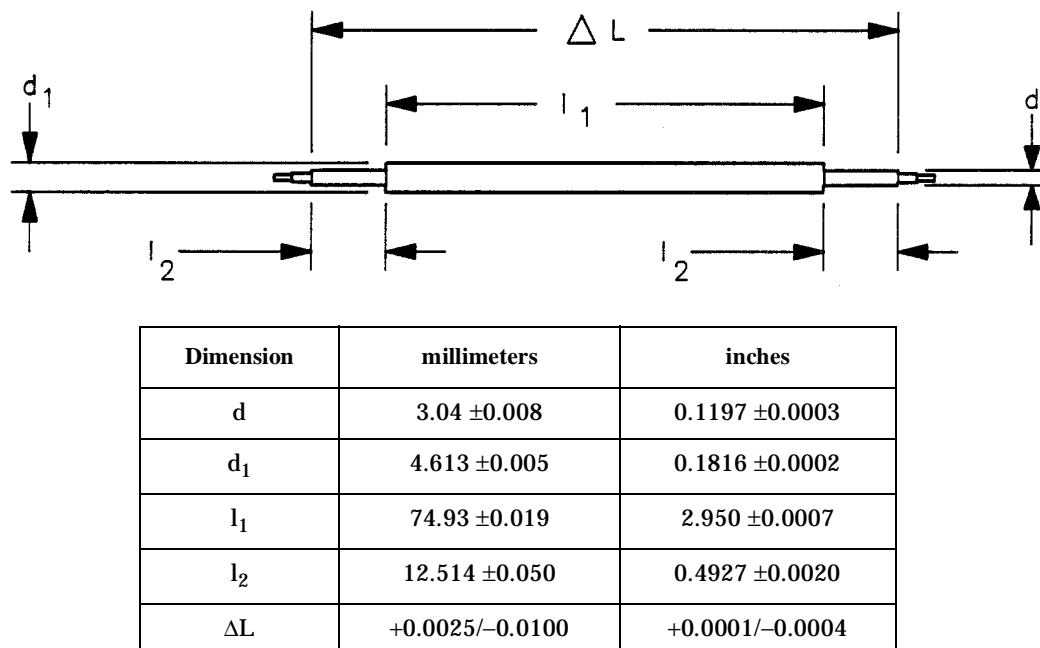

Figure 2-4 25 Ω Mismatch Airline Center Conductor



Electrical Specifications

At the factory, each verification device is electrically characterized on a network analyzer measurement system. These factory measurements are traceable to the National Institute of Standards and Technology (NIST) through mechanical and electrical paths (for more information on traceability, contact Agilent Technologies. Refer to [Table 6-1 on page 6-4](#) for a list of contacts.

The factory-measured data for each device is supplied in print and on disk with your kit.

3 Duplicating Your Verification Data

Using an 8510C Network Analyzer

1. Initialize a blank disk:
 - a. Insert a blank disk in the 85101 disk drive and press [TAPE/DISC].
 - b. Select **STORAGE IS INTERNAL, SETUP DISC, INITIALIZE DISC, YES**.
2. Insert the *original* data disk (it came in your verification kit) in the 85101 disk drive.
3. Press [TAPE/DISC] and select **LOAD, MEMORY ALL**. After you note the file numbers that have an asterisk next to them, select **FILE 1**.
4. When file 1 is through loading, remove the *original* disk and insert the blank, initialized disk in the disk drive.
5. Duplicate the S-Parameters:
 - a. Press [TAPE/DISC] and select **STORE, MEMORY ALL, FILE 1**.
 - b. Repeat steps 2 through 5a, substituting the next file number with an asterisk (noted in step 3) for **FILE 1** until all the files with an asterisk are copied on the new disk.
6. Duplicate the uncertainty limits:
 - a. Insert the *original* data disk in the disk drive.
 - b. Press [LOAD] and select **LOAD MEMORY 1-8**. Note the memory locations that have an asterisk next to them and select 1.
 - c. Note the file numbers that have an asterisk next to them and select **FILE 1**.
 - d. When file 1 memory location 1 is through loading, remove the *original* disk and insert the blank, initialized disk in the disk drive.
 - e. Press [TAPE/DISC] and select **STORE, MEMORY 1-8, 1, FILE 1**.
 - f. Repeat steps 6a through 6e substituting the appropriate memory locations (noted in step 6b) and files (noted in step 6c) until all files in all memory locations are copied on the new disk.
7. Verify the new disk has duplicated properly by pressing [TAPE/DISC] and selecting **DIRECTORY**. The screen displays four **MEMORY ALL** files and four **MEMORY 1-8** files.
8. Remove the data disk from the disk drive.
9. Write-protect the disk and label it.

Using an HP Series 200/300 Controller

The procedures that follow describe how to make a backup copy of the data disk. The first procedure is fast, but requires the HP series 200/300 controller, and the HP 9122 disk drive. The second procedure requires an Agilent 8719, 8720, or 8722 network analyzer, and the HP 9122 disk drive.

NOTE The disks supplied for use with the 8719, 8720, and 8722 series analyzers are formatted using Logical Interchange Format (LIF) and, therefore, cannot be duplicated on a personal computer (PC).

1. Load the BASIC operating system into the controller memory.
2. Write-protect the master disk. To do this, slide the tab at the bottom edge of the disk so that the small square is open; you should be able to see through the square.
3. Write-enable the blank disk. To do this, slide the tab at the bottom edge of the disk so that the small square is filled; you should *not* be able to see through the square.
4. Insert the blank disk in drive 0.
5. Insert the master disk in drive 1.
6. Type the following to initialize the blank disk:
 INITIALIZE “:,700,0”
7. Type the following to copy the entire master disk to the blank disk:
 COPY “:,700,1” to “:,700,0”

Using an 8719, 8720, or 8722 Series Network Analyzer

1. Write-protect the master disk. To do this, slide the tab at the bottom edge of the disk so that the small square is open; you should be able to see through the square.
2. Write-enable the blank disk. To do this, slide the tab at the bottom edge of the disk so that the small square is filled; you should *not* be able to see through the square.
3. Press **[PRESET]** on the analyzer.
4. Insert the blank disk in drive 0.
5. Insert the master disk in drive 1.
6. Press the following keys on the analyzer to initialize the blank disk:
 - [LOCAL], SYSTEM CONTROLLER.** The analyzer is now controlling the disk drive.
 - DISK, UNIT NUMBER, [0], [x1]** to select the blank disk.
 - [SAVE], STORE TO DISK, DEFINE STORE, INITIALIZE DISK, YES.** The blank disk is now initialized.
7. Press the following keys to get the first set of files from the master disk:
 - [LOCAL], DISK UNIT NUMBER, [1], [x1]**
 - [RECALL], LOAD FROM DISK, READ FILE TITLES.** The first set of file titles is now displayed beside the softkeys.
8. Press the following keys to load the first file into the analyzer:
 - [LOCAL], DISK UNIT NUMBER, [1], [x1]**
 - [RECALL], LOAD FROM DISK**
 - LOAD (filename)**
9. Press the following keys to store the first file onto the blank disk:
 - [LOCAL], DISK UNIT NUMBER, [0], [x1]**
 - [SAVE], STORE TO DISK**
 - STORE (filename)**
10. This sequence has transferred the first file from the master disk to the blank disk. Repeat steps 7 and 8 to transfer the other titles shown on the softkey labels.
11. Repeat steps 6, 7, and 8 until all sets of files have been transferred.

Using a PNA Series Network Analyzer

The procedure for duplicating a data disk using a PNA series analyzer is essentially the same as for a personal computer (PC).

NOTE The disk supplied for use with the PNA series analyzers is formatted using MS-DOS® and, therefore, can be duplicated on a personal computer (PC).

The blank disk must be formatted before it can be written to. If you already have a formatted disk, proceed to [“Copy the Data Disk.”](#)

Format a Blank Disk

Mouse Procedure

1. Write-enable the blank disk. To do this, slide the tab at the bottom edge of the disk so that the small square is filled; you should *not* be able to see through the square.
2. Insert the disk to be formatted in the analyzer’s disk drive.
3. Click the **My Computer** icon, and then highlight the icon for the analyzer’s disk drive. *Do not* click the disk icon because this will open the disk drive, and you can not format a disk if it is open in **My Computer**. (To display the **My Computer** icon: on the **System** menu, click **Windows Task Bar**, and then click the **Show Desktop** icon.)
4. On the **File** menu, click **Format**.
 - Formatting a disk removes all information from the disk.
 - You cannot format a disk if there are files open on that disk.
5. Follow the instructions as they appear. For help on an item, click the ? icon at the top of the dialog box, and then click the item.
6. Remove the disk from the disk drive when finished.

Copy the Data Disk

Mouse Procedure

1. Write-protect the blank disk. To do this, slide the tab at the bottom edge of the disk so that the small square is open; you should be able to see through the square.
2. Insert the disk to be copied in the analyzer’s disk drive. You can use the same disk drive for both disks.
3. Click the **My Computer** icon, and then click the icon for the analyzer’s disk drive to open it. (To display the **My Computer** icon: on the **System** menu, click **Windows Task Bar**, and then click the **Show Desktop** icon.)
4. On the **Edit** menu, click **Select All**.

MS-DOS is a U.S. registered trademark of Microsoft Corporation.

5. On the **Edit** menu, click **Copy**. Wait for the file copy function to complete.
6. Remove the master disk and insert the formatted disk in the analyzer's disk drive.
7. On the **Edit** menu, click **Paste**.
8. Remove the disk from the disk drive when finished.

4 Use, Maintenance, and Care of the Devices

Electrostatic Discharge

Protection against electrostatic discharge (ESD) is essential while connecting, inspecting, or cleaning connectors attached to a static-sensitive circuit (such as those found in test sets).

Static electricity can build up on your body and can easily damage sensitive internal circuit elements when discharged. Static discharges too small to be felt can cause permanent damage. Devices such as calibration components and devices under test (DUT), can also carry an electrostatic charge. To prevent damage to the test set, components, and devices:

- *always* wear a grounded wrist strap having a 1 M Ω resistor in series with it when handling components and devices or when making connections to the test set.
- *always* use a grounded, conductive table mat while making connections.
- *always* wear a heel strap when working in an area with a conductive floor. If you are uncertain about the conductivity of your floor, wear a heel strap.
- *always* ground the center conductor of a test cable before making a connection to the analyzer test port or other static-sensitive device. This can be done as follows:
 1. Connect a short (from your calibration kit) to one end of the cable to short the center conductor to the outer conductor.
 2. While wearing a grounded wrist strap, grasp the outer shell of the cable connector.
 3. Connect the other end of the cable to the test port.
 4. Remove the short from the cable.

Figure 4-1 shows a typical ESD protection setup using a grounded mat and a wrist strap. Refer to Table 7-2 on page 7-3 for information on ordering supplies for ESD protection.

Figure 4-1 ESD Protection Setup

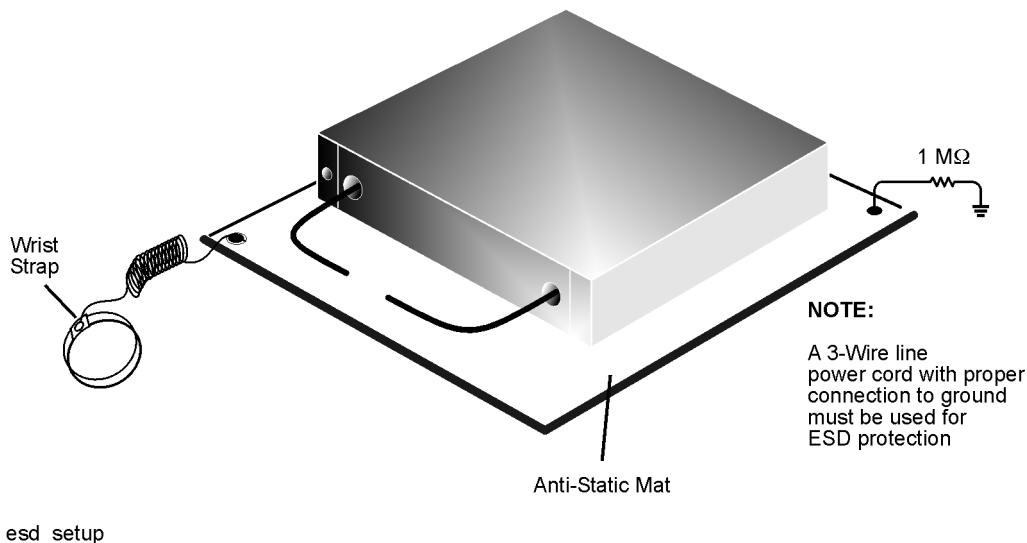

Visual Inspection

Visual inspection and, if necessary, cleaning should be done every time a connection is made. Metal particles from the connector threads may fall into the connector when it is disconnected.

CAUTION Devices with damaged connectors should be immediately discarded or clearly marked and set aside for repair. A damaged device will in turn damage any good connector to which it is attached. Determine the cause of the damage before connecting a new, undamaged connector in the same configuration.

In some cases, magnification is necessary to see damage to a connector; a magnifying device with a magnification of $\geq 10\times$ is recommended. However, not all defects that are visible only under magnification will affect the electrical performance of the connector. Use the following guidelines when evaluating the integrity of a connector.

Look for Obvious Defects and Damage First

Examine the connectors first for obvious defects or damage: badly worn plating on the connector interface, deformed threads or bent, broken, or misaligned center conductors. Connector nuts should move smoothly and be free of burrs, loose metal particles, and rough spots.

What Causes Connector Wear?

Connector wear is caused by connecting and disconnecting the devices. The more use a connector gets, the faster it wears and degrades. The wear is greatly accelerated when connectors are not kept clean, or are not connected properly.

Connector wear eventually degrades performance of the device. Calibration devices should have a long life if their use is on the order of a few times per week. Replace devices with worn connectors.

The test port connectors on the network analyzer test set may have many connections each day, and are therefore more subject to wear. It is recommended that an adapter be used as a test port saver to minimize the wear on the test set's test port connectors.

Inspect the Mating Plane Surfaces

Flat contact between the connectors at all points on their mating plane surfaces is required for a good connection. Look especially for deep scratches or dents, and for dirt and metal particles on the connector mating plane surfaces. Also look for signs of damage due to excessive or uneven wear or misalignment.

Light burnishing of the mating plane surfaces is normal, and is evident as light scratches or shallow circular marks distributed more or less uniformly over the mating plane surface. Other small defects and cosmetic imperfections are also normal. None of these affect electrical or mechanical performance. If a connector shows deep scratches or dents, particles clinging to the mating plane surfaces, or uneven wear, clean and inspect it again.

Cleaning Connectors

1. Use Compressed Air or Nitrogen

Clean connectors are essential for ensuring the integrity of RF and microwave coaxial connections.

WARNING **Always use protective eyewear when using compressed air or nitrogen.**

Use compressed air (or nitrogen) to loosen particles on the connector mating plane surfaces.

You can use any source of clean, dry, low-pressure compressed air or nitrogen that has an effective oil-vapor filter and liquid condensation trap placed just before the outlet hose.

Ground the hose nozzle to prevent electrostatic discharge, and set the air pressure to less than 414 kPa (60 psi) to control the velocity of the air stream. High-velocity streams of compressed air can cause electrostatic effects when directed into a connector. These electrostatic effects can damage the device. Refer to [“Electrostatic Discharge” on page 4-2](#) for additional information.

2. Clean the Connector Threads

WARNING **Keep isopropyl alcohol away from heat, sparks, and flame. Store in a tightly closed container. It is extremely flammable. In case of fire, use alcohol foam, dry chemical, or carbon dioxide; water may be ineffective.**

Use isopropyl alcohol with adequate ventilation and avoid contact with eyes, skin, and clothing. It causes skin irritation, may cause eye damage, and is harmful if swallowed or inhaled. It may be harmful if absorbed through the skin. Wash thoroughly after handling.

In case of spill, soak up with sand or earth. Flush spill area with water.

Dispose of isopropyl alcohol in accordance with all applicable federal, state, and local environmental regulations.

Use a lint-free swab or cleaning cloth moistened with isopropyl alcohol to remove any dirt or stubborn contaminants on a connector that cannot be removed with compressed air or nitrogen. Refer to [Table 7-2 on page 7-3](#) for part numbers for isopropyl alcohol and cleaning swabs.

- a. Apply a small amount of isopropyl alcohol to a lint-free cleaning swab.
- b. Clean the connector threads.

- c. Let the alcohol evaporate, then blow the threads dry with a gentle stream of clean, low-pressure compressed air or nitrogen. Always completely dry a connector before you reassemble or use it.

3. Clean the Mating Plane Surfaces

- a. Apply a small amount of isopropyl alcohol to a lint-free cleaning swab.
- b. Clean the center and outer conductor mating plane surfaces. Refer to [Figure 2-1 on page 2-3](#). When cleaning a female connector, avoid snagging the swab on the center conductor contact fingers by using short strokes.
- c. Let the alcohol evaporate, then blow the connector dry with a gentle stream of clean, low-pressure compressed air or nitrogen. Always completely dry a connector before you reassemble or use it.

4. Inspect

Inspect the connector to make sure that no particles or residue remain. Refer to [“Visual Inspection” on page 4-3](#).

Gaging Connectors

The gages available from Agilent Technologies are intended for preventive maintenance and troubleshooting purposes only. They are effective in detecting excessive center conductor protrusion or recession, and conductor damage on DUTs, test accessories, and the calibration kit devices. *Do not use the gages for precise pin depth measurements.*

Connector Gage Accuracy

The connector gages are only capable of performing coarse measurements. They do not provide the degree of accuracy necessary to precisely measure the pin depth of the kit devices. This is partially due to the repeatability uncertainties that are associated with the measurement. Only the factory—through special gaging processes and electrical testing—can accurately verify the mechanical characteristics of the devices.

With proper technique, the gages are useful in detecting gross pin depth errors on device connectors. To achieve maximum accuracy, random errors must be reduced by taking the average of at least three measurements having different gage orientations on the connector. Even then, the resultant average can be in error by as much as ± 0.0001 inch due to systematic (biasing) errors usually resulting from worn gages and gage masters. As the gages undergo more use, the systematic errors can become more significant in the accuracy of the measurement.

When to Gage Connectors

Gage a connector at the following times:

- Prior to using a device for the first time: record the pin depth measurement so that it can be compared with future readings. This serves as a good troubleshooting tool when you suspect damage may have occurred to the device.

NOTE When measuring pin depth, the measured value (resultant average of three or more measurements) is not the true value. This is due to measurement uncertainties described earlier under “[Connector Gage Accuracy](#).” Always compare the measured value with the pin depth specifications in [Table 2-2 on page 2-4](#) and with previously recorded values to evaluate the condition of device connectors.

- If either visual inspection or electrical performance suggests that the connector interface may be out of typical range (due to wear or damage, for example).
- If a verification device is used by someone else or on another system or piece of equipment.
- Initially after every 100 connections, and after that as often as experience indicates.

Reading the Connector Gage

The gage dial is divided into increments of 0.0001 inch and major divisions of 0.001 inch (see Figure 4-2). For each revolution of the large dial, the smaller dial indicates a change of 0.01 inch. Use the small dial as the indicator of multiples of 0.01 inch. In most connector measuring applications, this value will be zero.

When making a measurement, the gage dial indicator will travel in one of two directions. If the center conductor is recessed from the *zero* reference plane, the indicator will move counterclockwise to indicate the amount of **recession**, which is read as a negative value. If the center conductor protrudes, the indicator will move clockwise to indicate the amount of **protrusion**, which is read as a positive value.

Figure 4-2 Reading the Connector Gage

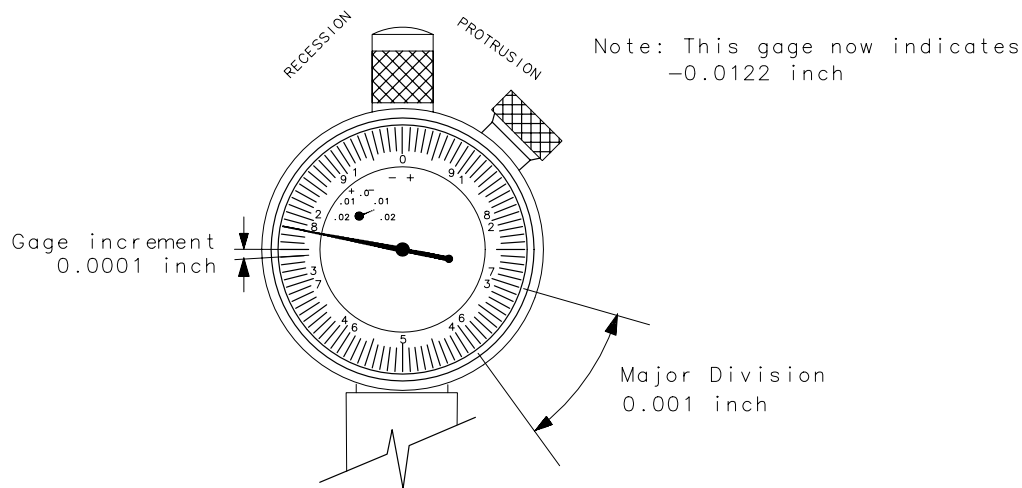

wj57f

Gaging Procedure

NOTE Always hold a connector gage by the gage barrel, below the dial indicator. This gives the best stability, and improves measurement accuracy.

1. Select the proper gage for your connector. Refer to [Table 7-2 on page 7-3](#) for gage part number.
2. Inspect and clean the gage, gage master, and device to be gaged. Refer to [“Visual Inspection” on page 4-3](#) and [“Cleaning Connectors” on page 4-4](#) of this chapter.
3. Zero the connector gage (refer to [Figure 4-3](#)):
 - a. While holding the gage by the barrel, and without turning the gage or the device, connect the gage master to the gage. Refer to [“Making Connections” on page 4-12](#) for more information. Connect the nut finger tight. Do not overtighten.
 - b. Using an open-end wrench to keep the gage from rotating, use the torque wrench recommended for use with the kit to tighten the gage master connector nut to the specified torque. Refer to [“Final Connection Using a Torque Wrench” on page 4-12](#) for more information.
 - c. The gage pointer should line up exactly with the zero mark on the gage. If not, loosen the dial lock screw on the gage and rotate the gage dial so that the pointer is aligned with the zero mark.
 - d. Tighten the dial lock screw and remove the gage master.
 - e. Attach and torque the gage master to the gage once again to verify that the setting is repeatable. Remove the gage master.
4. Gage the device connector (refer to [Figure 4-3](#)):
 - a. While holding the gage by the barrel, and without turning the gage or the device, connect the gage master to the gage. Refer to [“Making Connections” on page 4-12](#) for more information. Connect the nut finger-tight. Do not overtighten.
 - b. Using an open-end wrench to keep the gage from rotating, use the torque wrench recommended for use with the kit to tighten the device connector nut to the specified torque. Refer to [“Final Connection Using a Torque Wrench” on page 4-12](#) for more information.
 - c. Gently tap the barrel of the gage with your finger to settle the gage reading.
 - d. Read the gage indicator dial. If the needle has moved clockwise, the center conductor is *protruding* by an amount indicated by the *black* numbers. If the needle has moved counterclockwise, the center conductor is *recessed* by an amount indicated by the *red* numbers.

For maximum accuracy, measure the connector a minimum of three times and take an average of the readings. After each measurement, rotate the gage a quarter-turn to reduce measurement variations that result from the gage or the connector face not being exactly perpendicular to the center axis.

- e. Compare the average reading with the pin depth specifications listed in [Table 2-2](#) on [page 2-4](#).
- f. Remove the device from the gage.

Figure 4-3 Gaging 7 mm Connectors

Zero the Connector Gage

- Connect the gage master to the gage.
- Torque the connecting nut.
- Loosen the dial lock screw.
- Rotate the gage dial so that the pointer is aligned with the zero mark.
- Tighten the dial lock screw.
- Remove the gage master.

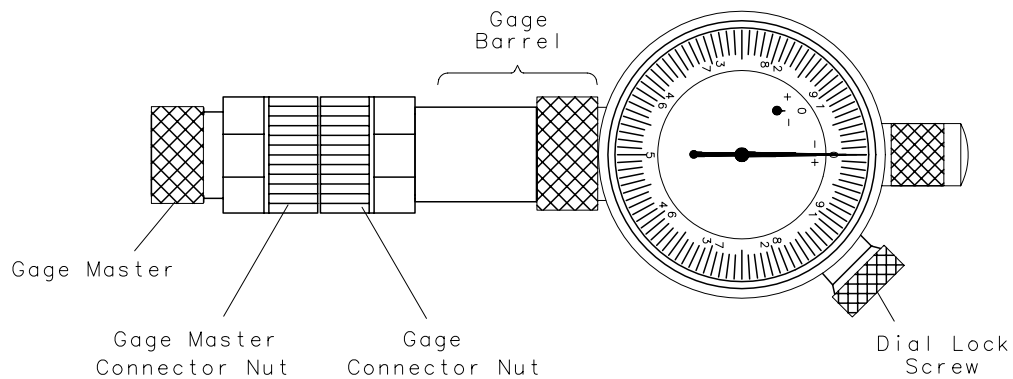

Gage the Device Connector

- Connect the device to the gage.
- Torque the connecting nut.
- Gently tap the gage barrel to settle the reading.
- Read recession or protrusion from the gage.
- Remove the device.
- Repeat two additional times and average the three readings.

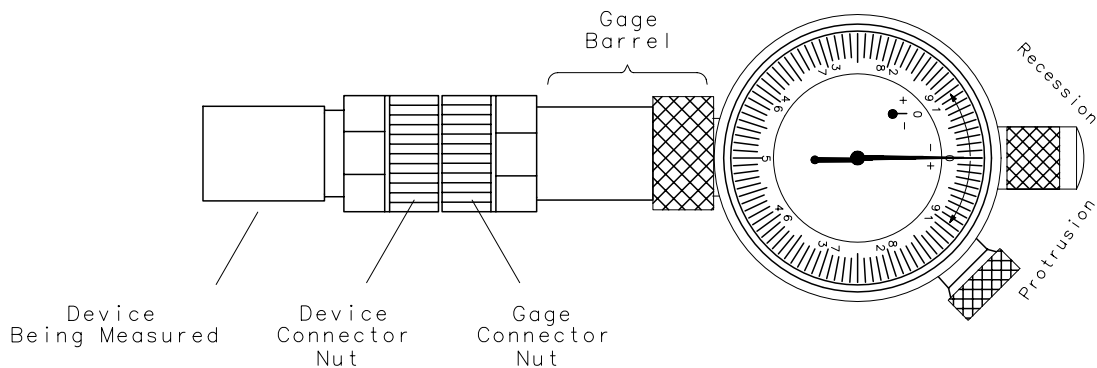

Gaging the Airline

The airline center and outer conductor in this kit are measured and matched for length at the factory using special fixtures and gages. Because the gages supplied in the calibration kits do not have the accuracy of the factory gages, use the following procedure for very general results only. Perform this procedure whenever you suspect that a center conductor has been switched with another airline or that a device has been damaged.

Attach the airline to the gage and short circuit

1. Inspect and, if required, clean the short, airline, and gage mating surfaces and threads.
2. Attach the short circuit from your calibration kit to the gage. Torque the connection to 136 N-cm, (12 in-lb). Refer to [Figure 4-4](#).

Figure 4-4 Gaging the Short Circuit

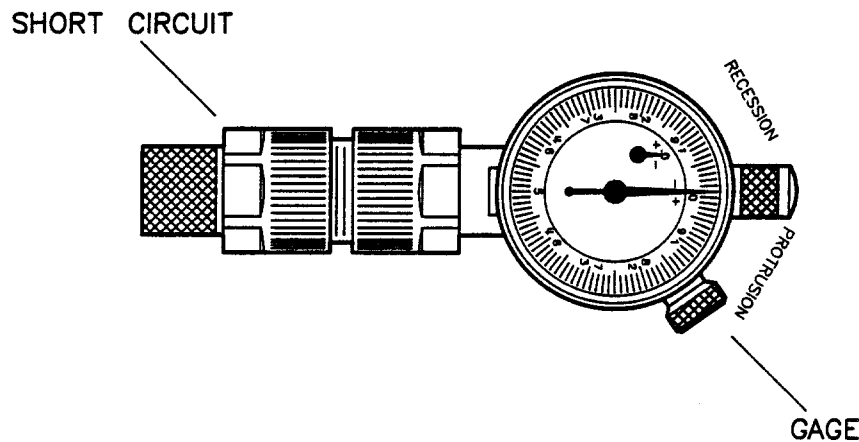

3. Gently tap the gage to settle the meter movement.
4. Adjust the dial on the gage to read flush (0.000) with the short circuit connected.
5. Remove the short circuit from the gage and attach the short circuit to the outer conductor of the airline. Refer to [Figure 4-5](#).
6. Remove the centering pins from the airline center conductor and slide the centering beads from the gage kit onto the airline center conductor.

NOTE This procedure refers to the “A” end of the airline as the end closest to the “A” in the Agilent logo on the label of the outer conductor. The other end will be referred to as the “B” end. See [Figure 4-8 on page 4-15](#).

7. Insert the center conductor into the outer conductor so that the mark on the center conductor is closest to the “A” end of the outer conductor. Do not let the center conductor scrape the edge of the outer conductor or damage may result.
8. Attach the gage to the other end of the airline. Refer to [Figure 4-5](#).

Figure 4-5 Gaging the Airline

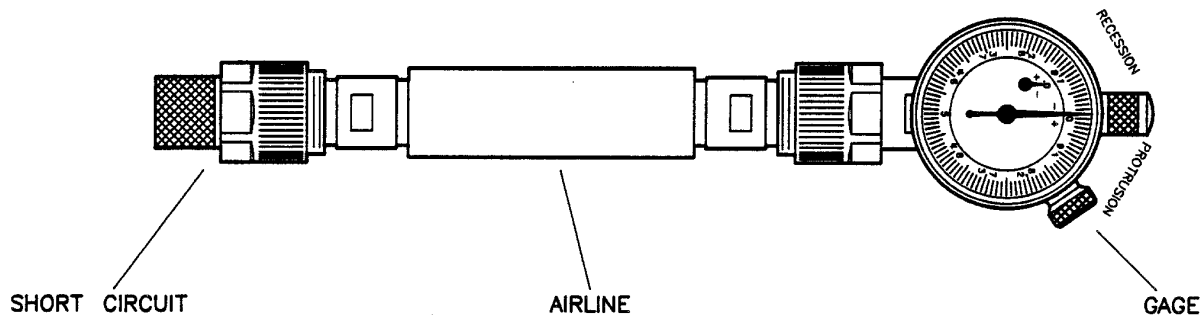

9. Torque the short circuit-to-airline connection and the gage-to-airline connection to 136 N-cm, (12 in-lb) with the 3/4 inch torque wrench. Set the assembly down to let the temperature stabilize for 5 minutes.
10. The reading on the gage should be within the tolerance band of the dimension given (± 0.0002 inch); ± 0.001 inch for factory uncertainties and ± 0.0001 inch for your gage accuracy.

NOTE The reading on the gage is an estimate of the actual recession of the center conductor. Gage accuracy is typically ± 0.0001 inch.

Disconnect the airline from the gage and short circuit

1. Remove one device from the airline and replace the plastic cap on the airline to prevent the center conductor from sliding out of the outer conductor.
2. Remove the device from the other end of the airline. If you won't be using the airline again immediately, slide the center conductor out of the outer conductor and store the center conductor in the plastic case provided. Replace the other plastic cap on the outer conductor and store the center and outer conductors in the foam lined storage case.

Making Connections

Good connections require a skilled operator. *The most common cause of measurement error is bad connections.* The following procedures illustrate how to make good connections.

How to Make a Connection

Preliminary Connection

1. Ground yourself and all devices. Wear a grounded wrist strap and work on a grounded, conductive table mat. Refer to [“Electrostatic Discharge” on page 4-2](#) for ESD precautions.
2. Visually inspect the connectors. Refer to [“Visual Inspection” on page 4-3](#).
3. If necessary, clean the connectors. Refer to [“Cleaning Connectors” on page 4-4](#).
4. Carefully align the connectors. The male connector center pin must slip concentrically into the contact finger of the female connector.
5. Push the connectors straight together and tighten the connector nut finger tight.

CAUTION Do *not* turn the device body. Turn only the connector nut. Damage to the center conductor can occur if the device body is rotated.

Do not twist or screw the connectors together. As the center conductors mate, there is usually a slight resistance.

6. The preliminary connection is tight enough when the mating plane surfaces make uniform, light contact. Do not overtighten this connection.

A connection in which the outer conductors make gentle contact at all points on both mating surfaces is sufficient. Very light finger pressure is enough to accomplish this.

7. Make sure the connectors are properly supported. Relieve any side pressure on the connection from long or heavy devices or cables.

Final Connection Using a Torque Wrench

Use a torque wrench to make a final connection. [Table 4-1](#) provides information about the torque wrench recommended for use with the calibration kit. A torque wrench is included in the calibration kit. Refer to [Table 7-2 on page 7-3](#) for part number and ordering information.

Table 4-1 Torque Wrench Information

Connector Type	Torque Setting	Torque Tolerance
7 mm	136 N-cm (12 in-lb)	±13.6 N-cm (±1.2 in-lb)

Using a torque wrench guarantees that the connection is not too tight, preventing possible connector damage. It also guarantees that all connections are equally tight each time.

Prevent the rotation of anything other than the connector nut that you are tightening. It may be possible to do this by hand if one of the connectors is fixed (as on a test port). However, it is recommended that you use an open-end wrench to keep the body of the device from turning.

1. Position both wrenches within 90 degrees of each other before applying force. See [Figure 4-6](#). Wrenches opposing each other (greater than 90 degrees apart) will cause a lifting action which can misalign and stress the connections of the devices involved. This is especially true when several devices are connected together.

Figure 4-6 Wrench Positions

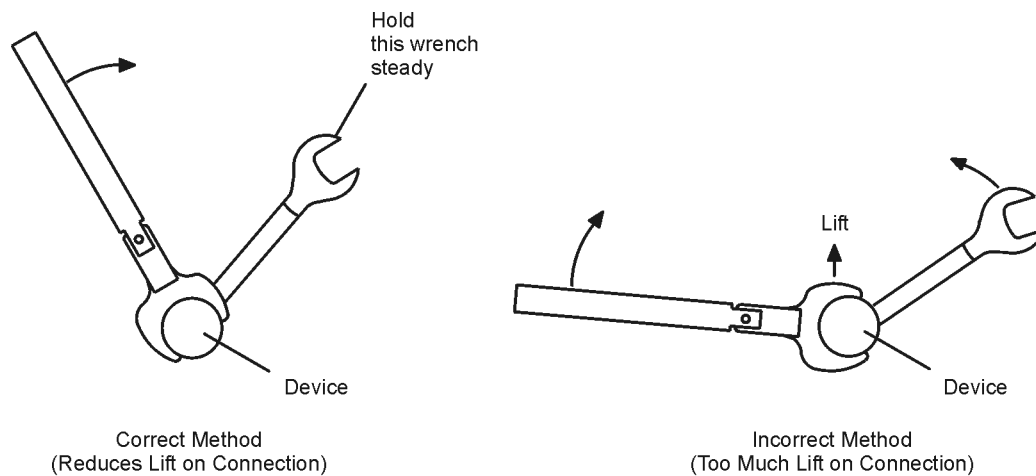

ph711a

2. Hold the torque wrench lightly, at the end of the handle only (beyond the groove). See [Figure 4-7](#).

Figure 4-7 Using the Torque Wrench

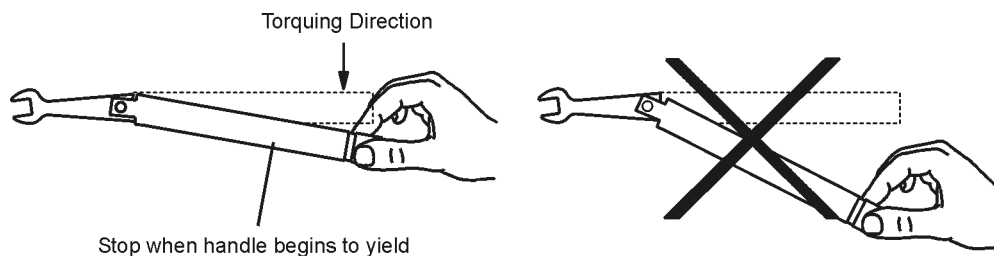

ph712a

3. Apply downward force perpendicular to the wrench handle. This applies torque to the connection through the wrench.

Do not hold the wrench so tightly that you push the handle straight down along its length rather than pivoting it, otherwise you apply an unknown amount of torque.

CAUTION You don't have to fully break the handle of the torque wrench to reach the specified torque; doing so can cause the handle to kick back and loosen the connection. Any give at all in the handle is sufficient torque.

4. Tighten the connection just to the torque wrench break point. The wrench handle gives way at its internal pivot point. See [Figure 4-7](#). Do not tighten the connection further.

Connecting the Airline

50Ω Airline and 25Ω Mismatch Airline

NOTE Before making any connections to the test set, be sure that bias power to the test set is OFF and take care to avoid electrostatic discharge. Refer to [“Electrostatic Discharge” on page 4-2](#).

CAUTION Be especially careful not to drop either the center conductor or the outer conductor when handling these airlines. Irreparable damage will result if these devices are dropped.

NOTE Detachable spring-loaded tips are supplied with the center conductors of both the airline and mismatch airline in your 85051B kit. Do not use these tips when connecting the airlines to the TRL adapters supplied in the 85050C 7 mm Precision Calibration Kit.

When you are using these airlines to verify analyzer performance affected with the 85050 7 mm Precision Calibration Kit, substitute the normal tips with the special colleted spring-loaded tips. These tips are included in your 85050C Calibration Kit to allow proper contact between the center conductors of the airlines and the non-colleted TRL adapters on the test ports. The colleted tips will not interfere when connecting the airlines to standard colleted test ports.

1. Connect test cables to port 1 and port 2 as they were connected during your calibration procedure.
2. Fully retract the threads on the port 1 cable connector.

NOTE This procedure refers to the “A” end of the airline as the end closest to the “A” in the Agilent logo on the label of the outer conductor. The other end will be referred to as the “B” end. See [Figure 4-8 on page 4-15](#).

Figure 4-8 Airline Center Conductor Placement

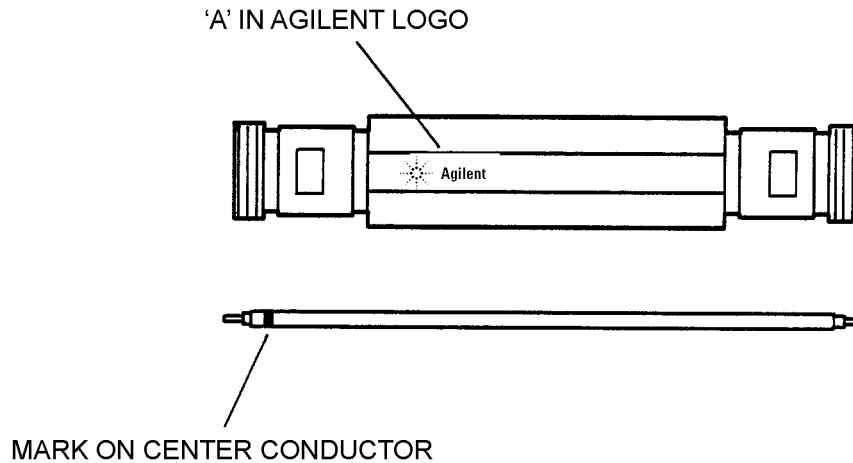

3. Remove the cap from the “A” end of the outer conductor. Leave the cap on the “B” end of the airline to prevent the center conductor from falling out of the airline.
4. Remove the center conductor from its plastic case. Make sure you select the correct center conductor for the airline you are connecting. Refer to [Figure 2-3](#) and [Figure 2-4 on page 2-5](#) for illustrations of both center conductors.
5. Insert the center conductor into the outer conductor so that the mark on the center conductor is closest to the “A” end of the outer conductor. See [Figure 4-8](#). Do not let the center conductor scrape the edge of the outer conductor or damage may result.
6. Bring the “A” end of the airline to the port 1 cable. Gently press on the cap at the “B” end of the airline so that the center conductor tip emerges from the “A” end of the airline. See [Figure 4-9](#).

Figure 4-9 Airline

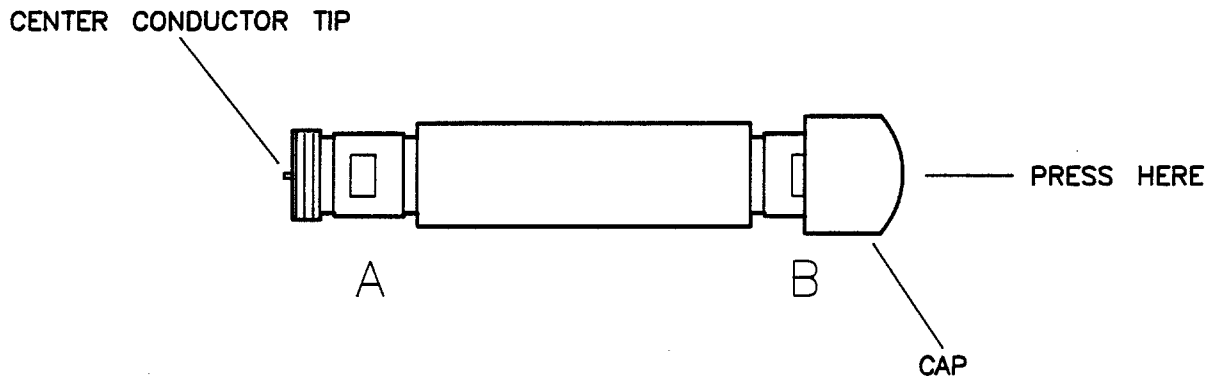

NOTE To avoid damaging the airline center conductor, always keep it in line with the connecting center pin.

7. Insert the tip of the center conductor (emerging from the “A” end) into the cable center conductor. See [Figure 4-10](#). Mate the outer conductors of the airline and port 1 cable connector finger tight.

Figure 4-10 Connecting the Airline

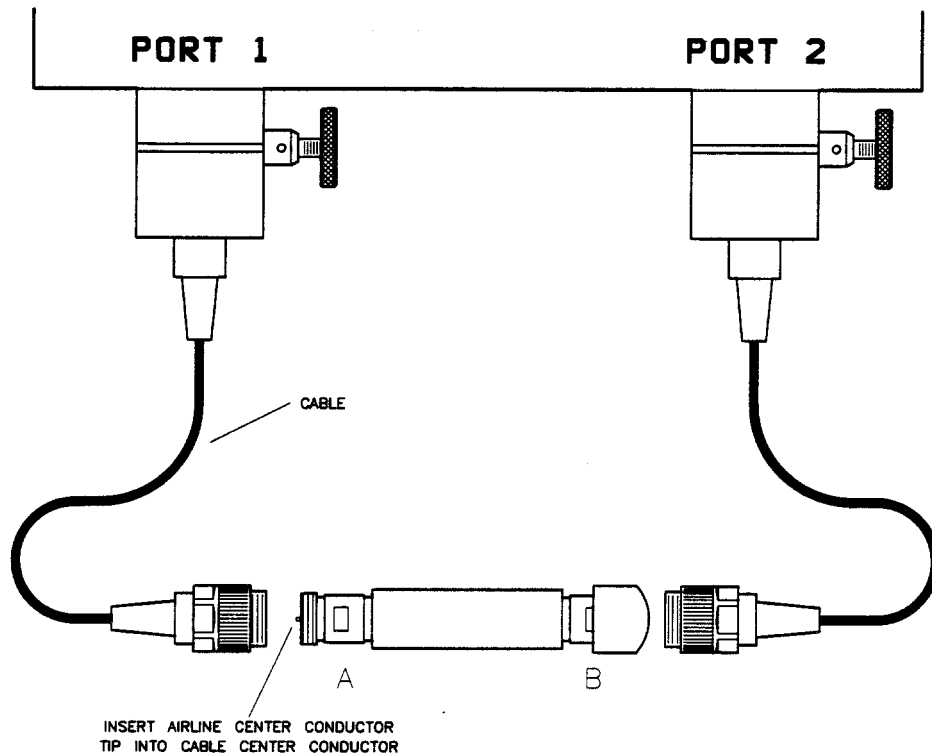

8. Gently remove the cap from the “B” end of the outer conductor. Fully retract the threads on the port 2 cable.
9. Align the center conductor of the port 2 cable connector with the center conductor of the airline. Insert the tip of the airline center conductor into the center conductor of the port 2 cable connector.
10. Mate the outer conductors of the port 2 cable connector and airline finger tight.
11. Torque the cable connectors as shown in [Figure 4-11](#) on page 4-17. To keep the airline from turning, either hold its plastic insulation or use an open end wrench while you torque the connection.

Figure 4-11 Torquing the Connection

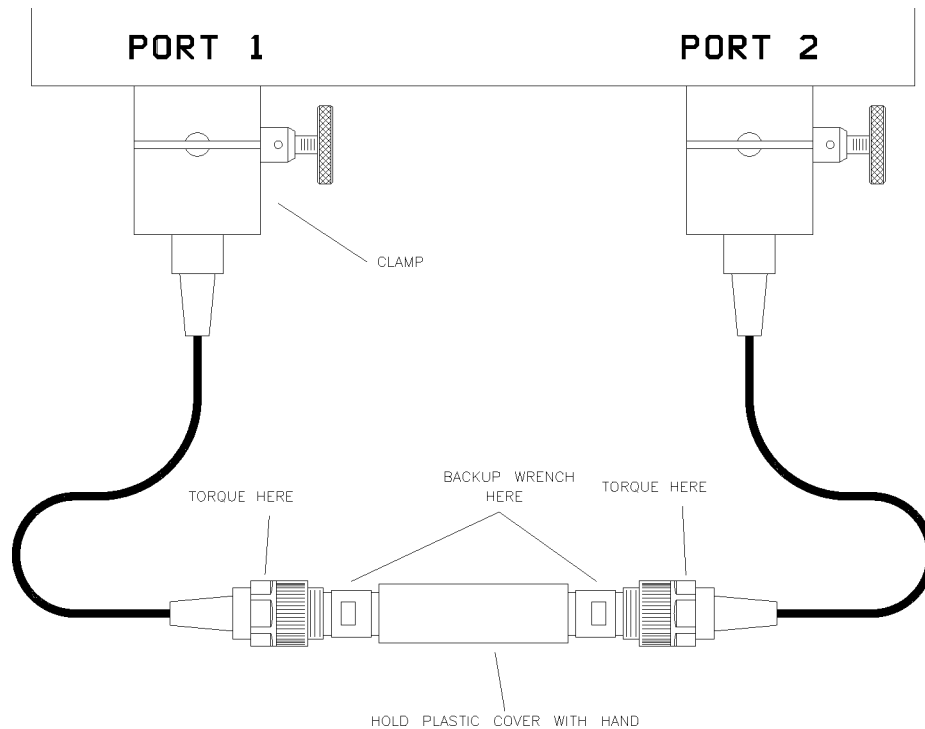

How to Separate a Connection

NOTE Do *not* turn the device body. Only turn the connector nut. Damage to the center conductor can occur if the device body is rotated.

1. Use an open-end wrench to prevent the device body from turning.
2. Use another open-end wrench to loosen the connector nut.
3. Complete the disconnection by hand, turning only the connector nut.
4. Pull the connectors straight apart without twisting, rocking, or bending either of the connectors.

NOTE If disconnecting an airline and the airline center conductor does not disengage from the device center conductor, gently pull the center conductors apart and then push the airline center conductor back inside the outer conductor of the airline.

Handling and Storage

- *Do* install the protective end caps and store the devices in the foam-lined storage case when not in use.
- *Do* keep connectors and airlines clean.
- *Do not* store connectors and airlines loose in a box, or in a desk or bench drawer. This is the most common cause of connector damage during storage.
- *Do not* touch mating plane surfaces. Natural skin oils and microscopic particles of dirt are easily transferred to a connector interface and are very difficult to remove.
- *Do not* set connectors contact-end down on a hard surface. The plating and the mating plane surfaces can be damaged if the interface comes in contact with any hard surface.

5 Performance Verification

Introduction

The performance of your verification kit can only be verified by returning the kit to Agilent Technologies for recertification. The equipment required to verify the specifications of the devices in the kit has been specially manufactured and is not commercially available.

How Agilent Verifies the Devices in Your Kit

Agilent verifies the specifications of these devices as follows:

1. The residual microwave error terms of the test system are verified with precision airlines and shorts that are directly traced to the National Institute of Standards and Technology (NIST). The airline and short characteristics are developed from mechanical measurements. The mechanical measurements and material properties are carefully modeled to give very accurate electrical representation. The mechanical measurements are then traced to NIST through various plug and ring gages and other mechanical measurements.
2. Each device is electrically tested on this system. For the initial (before sale) testing of the devices, Agilent includes the test measurement uncertainty as a guardband to guarantee each device meets the published specification. For recertifications (after sale), no guardband is used and the measured data is compared directly with the specification to determine the pass or fail status. The measurement uncertainty for each device is, however, recorded in the calibration report that accompanies recertified kits.

These two steps establish a traceable link to NIST for Agilent to the extent allowed by the institute's calibration facility. The specifications data provided for the devices in the kit is traceable to NIST through Agilent Technologies.

Recertification

The following will be provided with a recertified kit:

- a new calibration sticker affixed to the case
- a certificate of calibration
- a calibration report for each device in the kit listing measured values, specifications, and uncertainties

NOTE A list of NIST traceable numbers may be purchased upon request to be included in the calibration report.

Agilent Technologies offers a *Standard* calibration for the recertification of the kit. For more information, contact Agilent Technologies. See [Table 6-1 on page 6-4](#) for contact information.

How Often to Recertify

The suggested initial interval for recertification is 12 months or sooner. The actual need for recertification depends on the use of the kit. After reviewing the results of the initial recertification, you may establish a different recertification interval that reflects the usage and wear of the kit.

NOTE The recertification interval should begin on the date the kit is *first used* after the recertification date.

Where to Send a Kit for Recertification

Contact Agilent Technologies for information on where to send your kit for recertification. Contact information is listed on [page 6-4](#). Refer to “[Returning a Kit or Device to Agilent Technologies](#)” on [page 6-4](#) for details on sending your kit.

6 Troubleshooting

Troubleshooting Process

If your network analyzer does not pass performance verification, follow the steps in [Figure 6-1](#) to determine the cause of the failure and the correct action to take to correct the failure.

Compatible Network Analyzers

The devices in this kit and their data are compatible with the following network analyzers:

- 8510 Series
- 8719 Series, 8720 Series, and 8722 Series
- PNA Series

The data disk provided for use with each of the above listed network analyzers contains the factory-measured S-parameter data for the devices in this kit. It also contains the uncertainty limits used in the system verification procedure. This data is unique to each kit.

The data disk provided for the 8719 and 8720-series analyzers is for verification kits with the serial number 2815A or higher. Kits ordered prior to this serial prefix can be upgraded to include the data disk by recertifying the kit through Agilent. Refer to [“Contacting Agilent” on page 6-4](#).

It is recommended that a backup copy of the data disk and the data printout be made immediately upon receipt of the verification disk. Refer to [Chapter 3](#), [“Duplicating Your Verification Data,”](#) for instructions.

Figure 6-1 Troubleshooting Flowchart

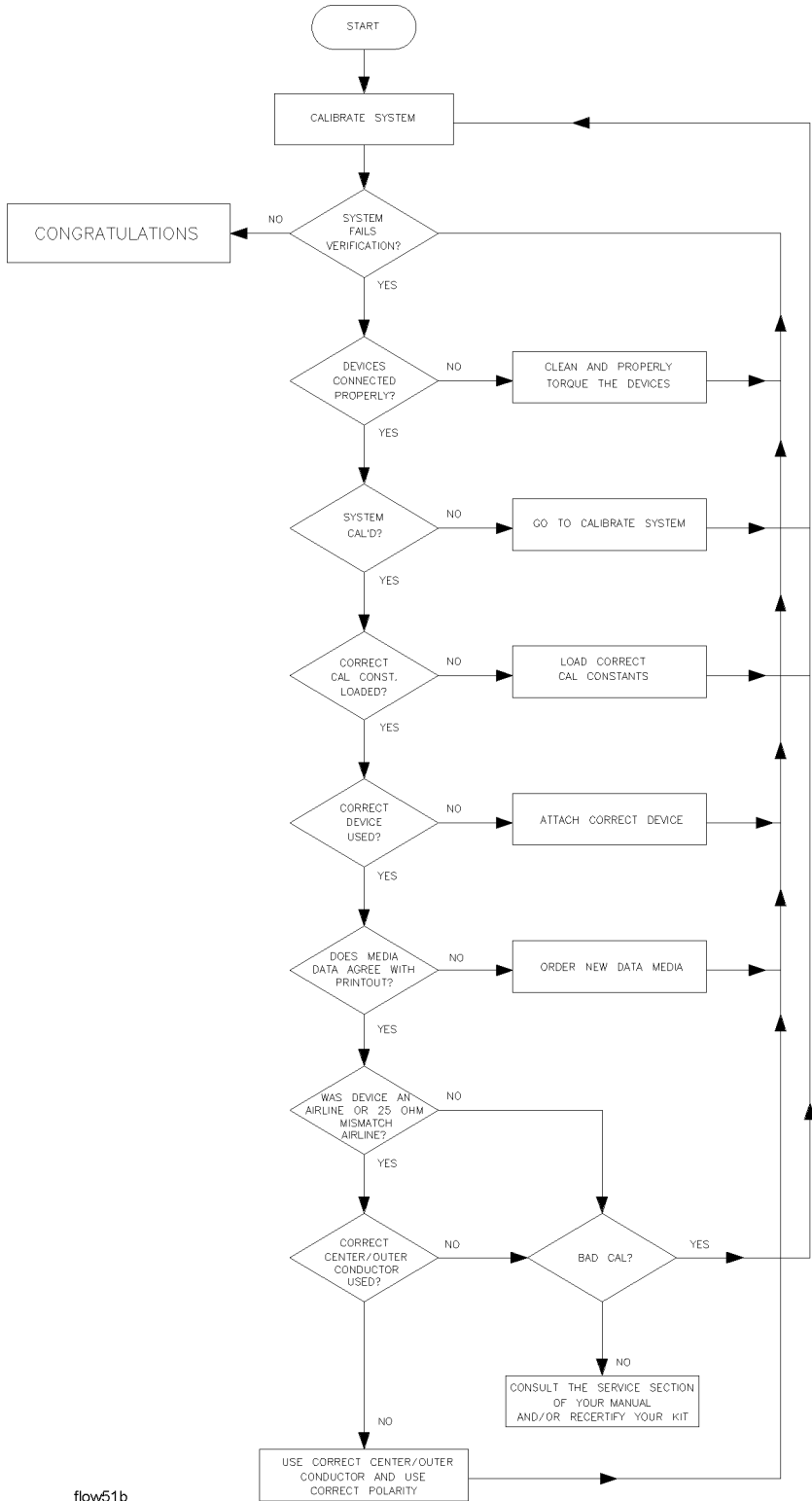

flow51b

Returning a Kit or Device to Agilent Technologies

If your kit or device requires service, contact Agilent Technologies for information on where to send it. See [Table 6-1](#) for contact information. Include a service tag (located at the back of this manual) on which you provide the following information:

- your company name and address.
- a technical contact person within your company, and the person's complete phone number including country code and area code.
- the model number and serial number of the kit (if returning a complete kit)
- the part number and serial number of each device being returned
- the type of service required
- a *detailed* description of the problem (if applicable) and how the device was being used when the problem occurred.

Contacting Agilent

Table 6-1 Contacting Agilent

Online assistance: www.agilent.com/find/assist			
United States <i>(tel)</i> 1 800 452 4844	Latin America <i>(tel)</i> (305) 269 7500 <i>(fax)</i> (305) 269 7599	Canada <i>(tel)</i> 1 877 894 4414 <i>(fax)</i> (905) 282-6495	Europe <i>(tel)</i> (+31) 20 547 2323 <i>(fax)</i> (+31) 20 547 2390
New Zealand <i>(tel)</i> 0 800 738 378 <i>(fax)</i> (+64) 4 495 8950	Japan <i>(tel)</i> (+81) 426 56 7832 <i>(fax)</i> (+81) 426 56 7840	Australia <i>(tel)</i> 1 800 629 485 <i>(fax)</i> (+61) 3 9210 5947	Singapore <i>(tel)</i> 1 800 375 8100 <i>(fax)</i> (65) 836 0252
Malaysia <i>(tel)</i> 1 800 828 848 <i>(fax)</i> 1 800 801 664	Philippines <i>(tel)</i> (632) 8426802 <i>(tel) (PLDT subscriber only):</i> 1 800 16510170 <i>(fax)</i> (632) 8426809 <i>(fax) (PLDT subscriber only):</i> 1 800 16510288	Thailand <i>(tel) outside Bangkok:</i> (088) 226 008 <i>(tel) within Bangkok:</i> (662) 661 3999 <i>(fax)</i> (66) 1 661 3714	Hong Kong <i>(tel)</i> 800 930 871 <i>(fax)</i> (852) 2506 9233
Taiwan <i>(tel)</i> 0800-047-866 <i>(fax)</i> (886) 2 25456723	People's Republic of China <i>(tel) (preferred):</i> 800-810-0189 <i>(tel) (alternate):</i> 10800-650-0021 <i>(fax)</i> 10800-650-0121	India <i>(tel)</i> 1-600-11-2929 <i>(fax)</i> 000-800-650-1101	

7 Replaceable Parts

Introduction

Table 7-1 lists the replacement part numbers for items included in the 85051B verification kit.

Table 7-2 lists the replacement part numbers for items not included in the verification kit that are either required or recommended for successful operation of the kit.

To order a listed part, note the description, the part number, and the quantity desired. Telephone or send your order to Agilent Technologies. See Table 6-1 on page 6-4 for contact information.

Table 7-1 Replaceable Parts for the 85051B 3.5 mm Verification Kit

Description	Qty Per Kit	Agilent Part Number
Attenuators		
20 dB attenuator with data	1	85051-60001
40 dB attenuator with data	1	85051-60002
Airlines		
50Ω airline with data	1	85051-60010
25Ω mismatch airline with data	1	85051-60011
Miscellaneous Items		
Open-end wrench 9/16 in. and 1/2 in.	1	8710-1770
Storage box assembly	1	85051-60009
Connector Care—Quick Reference Card	1	08510-90360
User's and Service Guide		
User's and service guide	1	85051-90031
Verification Data Media		
Verification data disk (8510 series)	1	85051-10003
Verification data disk (8719 and 8720)	1	85051-10002
Verification data disk (PNA series)	1	85051-10004

Table 7-2 Items Not Included in the Verification Kit

Description	Qty	Agilent Part Number
Connector Gages (7 mm)		
7 mm gage set ^a	1	85050-80012
Wrenches		
3/4 in, 135 N-cm (12 in-lb) torque wrench ^b	1	8710-1766
7 mm collet extractor tool ^a	1	5060-0370
Miscellaneous Items		
7 mm short ^b	1	85050-80008 (85050C Cal Kit) –Or– 85050-80007 (85050B and 85050D Cal Kit)
ESD Protection Devices		
Grounding wrist strap ^b	1	9300-1367
5 ft grounding cord for wrist strap ^b	1	9300-0980
2 x 4 ft conductive table mat and 15 ft ground wire ^b	1	9300-0797
ESD heel strap (for conductive floors) ^b	1	9300-1308
Connector Cleaning Supplies		
Isopropyl alcohol ^b	30 ml	8500-5344
Cleaning swabs ^b	100	9301-1243

a. Included in the 85050B and 85050C 7 mm calibration kits.

b. Included in the 85050B, 85050C, and 85050D 7 mm calibration kits.

Figure 7-1 Replaceable Parts

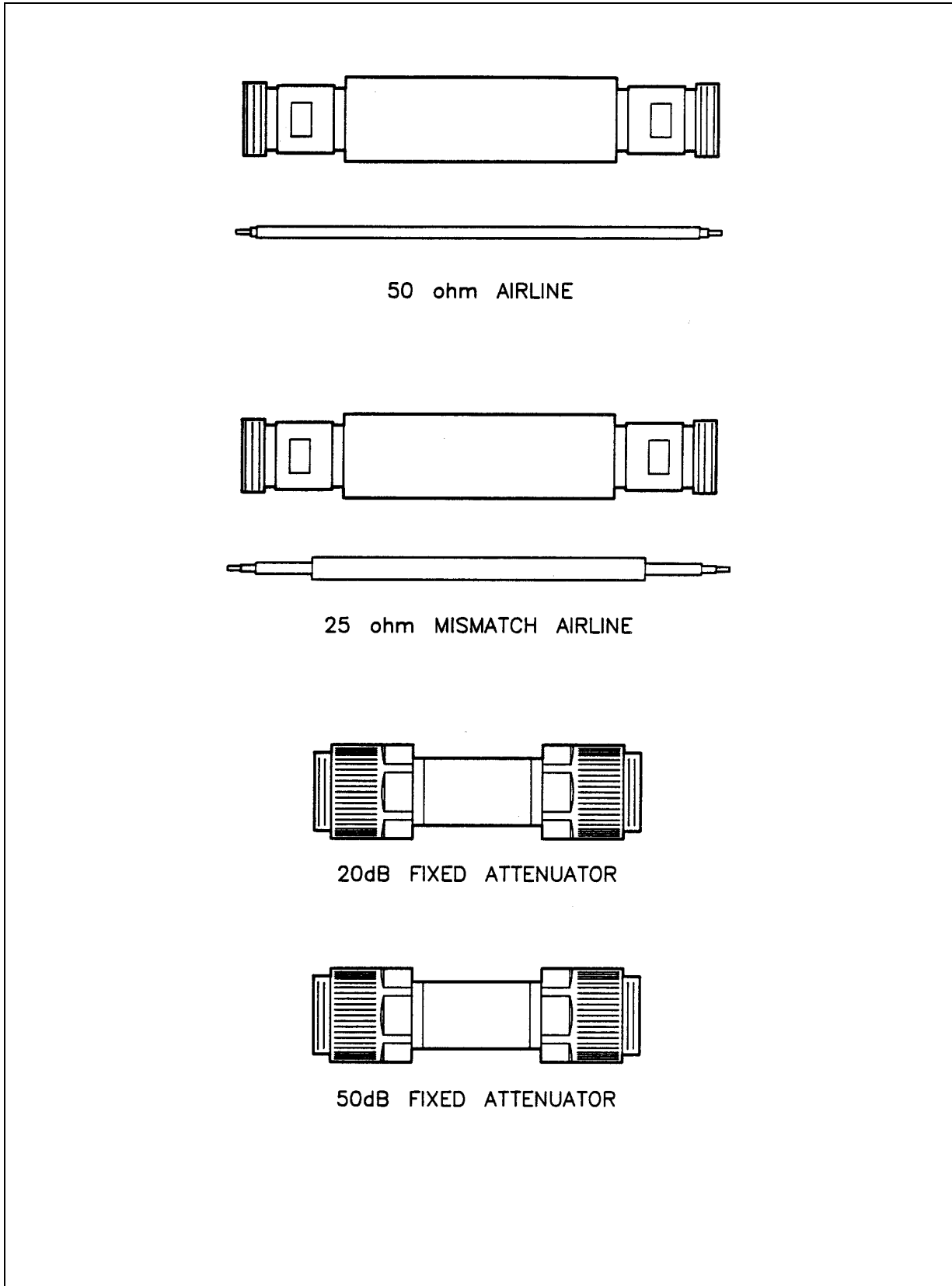

Numerics

25 ohm airline assembly and connection, 4-14
50 ohm airline, assembly and connection, 4-14

A

Agilent Technologies
 contacting, 6-4
agreements
 customer assistance, ii
 warranty, ii
airline
 connection, 4-14
 dimensions, 2-4
 center conductor, 2-5
 outer conductor, 2-5
 disconnecting, 4-17
 gaging, 4-10
 mechanical characteristics, 2-4
 mismatch, 2-5
 part numbers, 7-2
alcohol
 isopropyl
 as cleaning solvent, 4-4
 precautions for use of, 4-4
altitude
 specifications, 2-2
assembling an airline, 4-14
assistance
 customer, ii
 who to contact, ii
attenuators
 part numbers, 7-2

B

box
 pads
 part numbers, 7-2
 part number, 7-2

C

calibration
 bad, 6-2
 certificate of, 5-3
 kits
 intended to be used, 1-2
 MIL-STD 45662, 5-3
 report, 5-3
 temperature, 2-2
case
 storage
 part number, 7-2
center conductor, 2-3
 protrusion, 4-7
 recession, 4-7
certificate of calibration, 5-3
characteristics
 mechanical, 2-3
 supplemental, 2-3
cleaning connectors, 4-4

compatibility
 with analyzers, 6-2
compressed air or nitrogen, 4-4
conductive table mat
 for ESD protection, 4-2
 part number, 7-3
conductor
 mating plane, 2-3
conductor, center, 2-3
connecting an airline, 4-14
connections, 4-2, 4-12
 ESD protection, 4-12
 final, 4-12
 preliminary, 4-12
 separating, 4-17
 using torque wrench, 4-12
connector
 cleaning, 4-4
 damage, 4-3
 defects, 4-3
 gage
 accuracy, 4-6
 dial, 4-7
 handling, 4-6, 4-8
 part numbers, 7-3
 reading, 4-7
 use of, 4-6
 zeroing, 4-6, 4-8
 gaging, 4-6
 to determine pin depth, 4-6
 when to do, 4-6
 male, 4-8
 mating plane surfaces, 2-3, 4-5
 cleaning, 4-5
 threads
 cleaning, 4-4
 inspecting, 4-3
 visual inspection, 4-3
 wear, 4-3
 affect on electrical performance, 4-3
contacting Agilent Technologies, 6-4
cord
 grounding
 part number, 7-3

D

damage
 caused by electrostatic discharge, 4-2
 device, 4-3
 inspecting for, 1-3, 4-3
 to connectors, 4-3
 what to do, 1-3
damaged connectors, 4-3
data disk
 duplicating
 8510C, 3-2
 8719/20/22, 3-3
 PNA Series, 3-5
 verification

Index

- part number, 7-2
- data recertification, 5-3
- defective connectors, 4-3
- defects
 - connector, 4-3
- device
 - compatibility
 - with analyzers, 6-2
 - conductor
 - mating plane, 2-3
 - connecting, 4-12
 - damage, 4-3
 - disconnecting, 4-17
 - handling, 4-18
 - maintenance, 1-4
 - performance
 - verifying, 5-2
 - specifications, 2-6
 - traceability, 5-2, 5-3
 - storage, 4-18
 - temperature, 2-2
 - visual inspection, 4-3
- dial
 - connector gage, 4-7
- dimensions
 - airline, 2-4
 - center conductor, 2-5
 - outer conductor, 2-5
 - device
 - center conductor, 2-3
 - outer conductor, 2-3
- disconnections, 4-17
- disk
 - duplicating
 - 8510C, 3-2
 - 8719/20/22, 3-3
 - PNA Series, 3-5
 - verification data
 - part number, 7-2
- documentation warranty, ii
- duplicating
 - verification data disk
 - 8510C, 3-2
 - verification disk
 - 8719/20/22, 3-3
 - PNA Series, 3-5

E

- electrical specifications, 2-6
- electrostatic discharge, *See* ESD
- environmental
 - regulations, 4-4
 - requirements, 2-2
 - specifications, 2-2
- equipment required, 1-3
- ESD, 4-2
 - conductive floor, 4-2
 - conductive table mat, 4-2
 - heel strap, 4-2
 - precautions, 4-2, 4-4

- protection, 4-2
- protection setup, 4-2
- supplies, 4-2
 - part numbers, 7-3
- wrist strap, 4-2

F

- flowchart
 - troubleshooting, 6-3
- frequency range, 1-2

G

- gage
 - connector
 - dial, 4-7
 - handling, 4-8
 - part numbers, 7-3
 - reading, 4-7
 - zeroing, 4-8
- gaging
 - airline, 4-10
 - connectors, 4-6
 - when to do, 4-6
 - male connectors, 4-8
 - to determine pin depth, 4-6
- grounding cord
 - part number, 7-3

H

- handling, 4-18
- heel strap
 - for ESD protection, 4-2
 - part number, 7-3
- humidity
 - specifications, 2-2

I

- incoming inspection, 1-3
- inspection
 - damage, 4-3
 - defects, 4-3
 - incoming, 1-3
 - mating plane surfaces, 4-3
 - visual, 4-3
- isopropyl alcohol
 - as cleaning solvent, 4-4
 - precautions for use of, 4-4

K

- kit
 - calibration
 - intended to be used, 1-2
 - contents, 1-2
 - frequency range, 1-2
 - overview, 1-2
 - performance
 - how Agilent verifies, 5-2
 - verifying, 5-2

M

- maintenance, 4-2
 - of devices, 1-4
 - preventive, 1-4
- making connections, 4-12
 - ESD protection, 4-12
 - precautions, 4-12
- manual
 - part number, 7-2
- mat
 - conductive
 - part number, 7-3
 - for ESD protection, 4-2
- mating plane
 - conductor, 2-3
 - surfaces
 - cleaning, 4-5
 - connector, 4-5
 - inspection of, 4-3
- mechanical characteristics, 2-3
 - verifying, 4-6
- mechanical integrity, 2-3
- MIL-STD 45662
 - calibration, 5-3
- mismatch airline, 2-5

N

- National Institute of Standards and Technology (NIST), 2-6, 5-2
- nitrogen, 4-4
- numbers
 - replaceable parts, 7-2
 - serial
 - recording, 1-4

O

- open-end
 - wrench
 - part number, 7-3
- open-end wrench, 4-17
- ordering parts, 7-2

P

- part numbers, 7-2
 - of items in kit, 7-2
 - of items not in kit, 7-3
- parts
 - included in kit, 7-2
 - not included in kit, 7-2, 7-3
 - ordering, 7-2
 - replaceable, 7-2
- performance verification
 - fail, 6-2
- pin depth
 - definition of, 2-3
 - gaging to determine, 4-6
 - specifications, 2-4
- preventive maintenance, 1-4
- protrusion

- center conductor, 4-7

R

- reading connector gage, 4-7
- recertification
 - how to order, 5-3
 - interval, 5-3
 - what's included, 5-3
 - where it's done, 5-3
- recession
 - center conductor, 4-7
- regulations
 - environmental, 4-4
- replaceable parts, 7-2
- report, calibration, 5-3
- requirements
 - environmental, 2-2
- return
 - kit or device to Agilent, 6-4

S

- separating connections, 4-17
- serial numbers
 - devices, 1-4
 - recording, 1-4
- service, 6-4
- service tag, 6-4
- shipment
 - verifying complete, 1-3
- specifications, 2-2
 - altitude
 - operating, 2-2
 - storage, 2-2
 - device, 2-6
 - electrical, 2-6
 - environmental, 2-2
 - humidity
 - operating, 2-2
 - storage, 2-2
 - pin depth, 2-4
 - temperature, 2-2
 - torque wrench, 4-12
 - traceability, 5-2, 5-3
- standards
 - National Institute of Standards and Technology (NIST), 5-2
- static discharge, *See* ESD
- storage, 4-18
- storage case
 - part number, 7-2
- strap
 - heel
 - part number, 7-3
 - wrist
 - part number, 7-3
- supplemental characteristics, 2-3

T

- table mat

Index

- for ESD protection, 4-2
- tag, service, 6-4
- temperature
 - affect on electrical performance, 2-2
 - calibration, 2-2
 - cautions about, 2-2
 - changes in, 2-2
 - device, 2-2
 - error-corrected, 2-2
 - measurement, 2-2
 - specifications, 2-2
 - operating, 2-2
 - storage, 2-2
 - verification and measurement, 2-2
- test data, 5-3
- threads
 - connector
 - cleaning, 4-4
 - inspecting, 4-3
- torque wrench
 - part number, 7-3
 - specifications, 4-12
- traceability
 - of device specifications, 5-2, 5-3
- troubleshooting, 6-2
 - flowchart, 6-3

U

- user's and service guide
 - part number, 7-2

V

- verification
 - temperature, 2-2
- verification data disk
 - duplicating
 - 8510C, 3-2
 - 8719/20/22, 3-3
 - PNA Series, 3-5
 - part number, 7-2
- verification kit
 - contents, 1-2
 - frequency range, 1-2
 - overview, 1-2
 - performance
 - how Agilent verifies, 5-2
 - verifying, 5-2
- visual inspection, 4-3

W

- warranty, documentation, ii
- wear
 - connector, 4-3
 - affect on electrical performance, 4-3
- wrench
 - open-end, 4-13, 4-17
 - part number, 7-3
 - proper positioning of, 4-13
 - torque, 4-12, 4-13

- part number, 7-3
- precautions for use of, 4-13
- proper use of, 4-13
- wrist strap
 - for ESD protection, 4-2
 - part number, 7-3

Z

- zeroing
 - connector gage, 4-8